

Filtered Pet Waterer

MODEL NO.

- 2000 SW
- 2000 MW
- 2000 LW

Model and serial number may be found at the rear of the waterer base.

Please record both model and serial number in a safe place for future use.

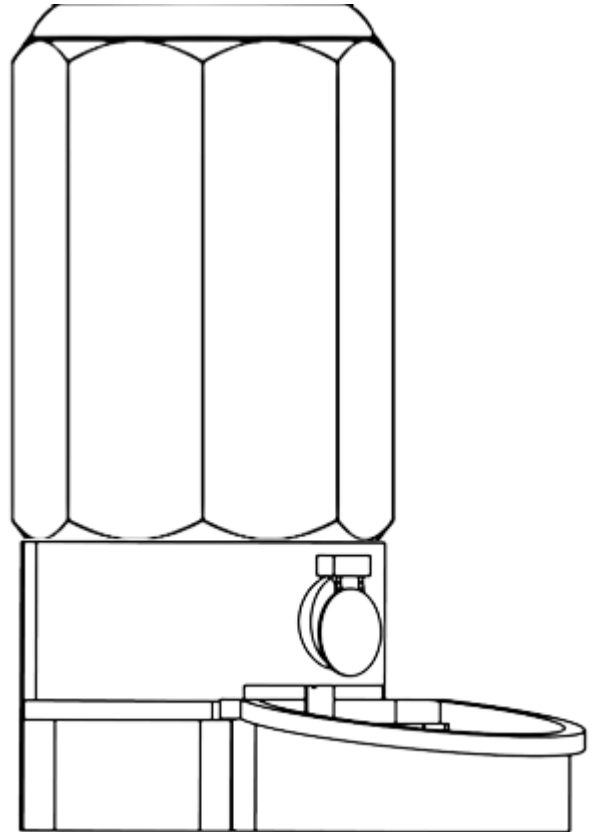

Where Purchased : _____
Date purchased : Month _____
: Day _____
: Year _____
Model No. : _____
Serial # : _____

This Owner's Manual contains information for all models.
Read and keep this manual for future reference.
This manual contains important information on Safety, Assembly, Operation and Maintenance.

Important: This is an Owner's Manual for Filtered Pet Waterer. Please do not discard this.

Congratulations on purchasing the "FILTERED PET WATERER". You will now have more time on your hands. Before you can use this appliance you need to follow some simple steps to assemble the Filtered Pet Waterer.



DO NOT RETURN THE PRODUCT TO THE STORE

Call 1-888 ERGOSYS (1-888-374-6797)

If there are missing parts. Check all packing for missing parts prior to discarding the package.

Before you call us, please have the following information ready.

1. Details of purchase like invoice number (found on the bill or invoice)
2. Name and model number of the product (found on the manual and on the carton.)
3. Actual problem after following the instructions.
4. List of missing parts.

LIMITED WARRANTY

Please read this warranty carefully. Ergo Systems Inc. will warranty this product to be free from manufacturing defects, including workmanship, when assembled and operated according to operating instructions enclosed with this product, for a period of ninety (90) days from the date of original purchase. This warranty is non-transferable and applies solely to the original purchaser and does not extend to subsequent owners of this product. Please register your product at <http://www.autopetfeeder.com>.

1. Repair service for a period of ninety (90) days from the date of original purchase at no charge for parts and labor with proof of purchase.
2. Replacement of defective parts for a period of 12 months from the date of original purchase with proof of purchase. (Labor not included after initial ninety (90) days.)
3. This warranty does not cover cost incurred in the shipping of the product to and from Ergo Systems Inc. for service. Shipping to Ergo Systems Inc. must be prepaid and insured by UPS or other parcel delivery services.

THIS WARRANTY IS VOID IF THE PRODUCT IS:

1. Damaged due to negligence, abuse, misuse, accident, modification, tampering, alteration, faulty installation and / or acts of God.
2. Used for commercial applications or rentals.
3. Modified or repaired by anyone other than Ergo Systems Inc.

The extent of Ergo Systems Inc. under this limited warranty is the repair or replacement of the product at the sole discretion of Ergo Systems Inc. In no event shall Ergo Systems Inc.'s liability exceed the purchase price paid by the purchaser. Under no circumstances shall Ergo Systems Inc. be liable for any loss, direct, indirect, incidental, foreseen, unforeseen, special or consequential damage arising out of or in connection with the use of this product. This warranty is valid only in the United States of America and Canada.

Reviewing these important safety alert symbols

When you see this Safety Symbol on the following pages, it will alert you to the possibility of damage to your Pet Waterer, if you do not comply with the corresponding instructions. The hazard may come from something mechanical or electrical. Read the instructions carefully.

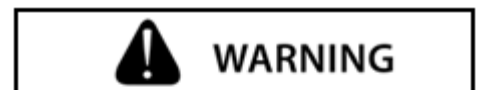

M E C H A N I C A L

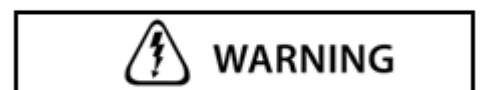

E L E C T R I C A L

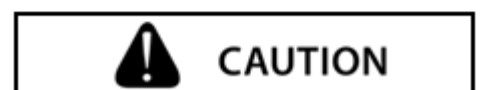

List of parts in the Filtered Pet Waterer Box

Components

1. Pet Waterer base
2. Pet Waterer bowl
3. Water Storage Container
4. Oval O-rings (Quantity 2)
5. Bowl nuts (Quantity 2).
6. 8 Layer Filter.
7. Filter cap.
8. Filter cover.
9. Check Valve.
10. Pump.
11. Transformer.
12. Flow tube.
13. Bottle stand.
14. Pre-filter.

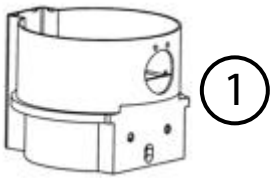

Pet Waterer Base

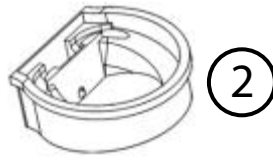

Pet Waterer Bowl

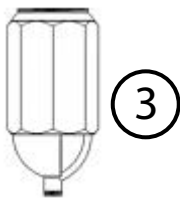

Water Storage Container

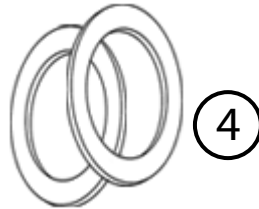

Oval O-Rings

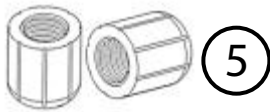

Bowl Nuts

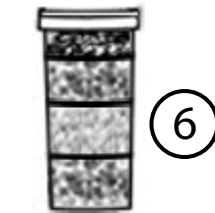

8 Layer Filter



Filter cap

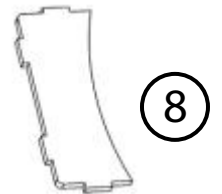

Filter Cover

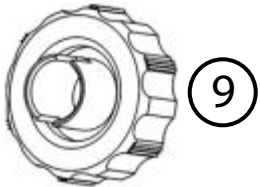

Check Valve



Pump

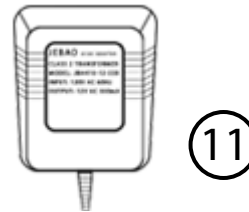

Transformer

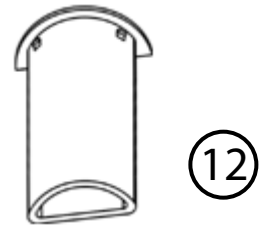

Flow tube

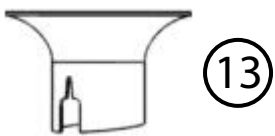

Bottle stand

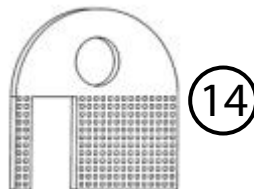

Pre-Filter

Assembly

1.1

- ❑ Take out the Filtered Pet Waterer from the box.

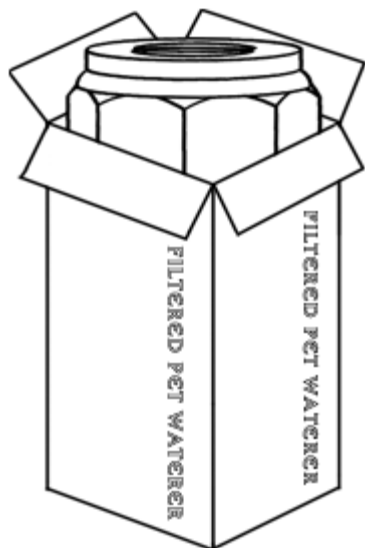

Fig 1

1.2

- ❑ Remove the water storage container from the base.

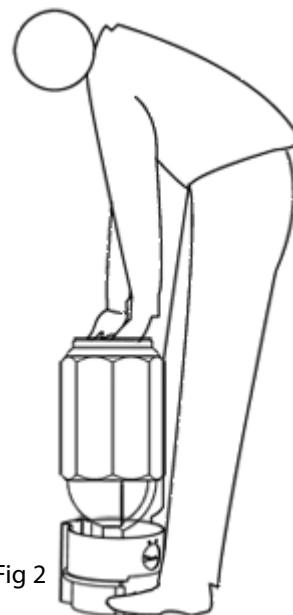

Fig 2

1.3

- ❑ Remove the bottle Stand from the base.

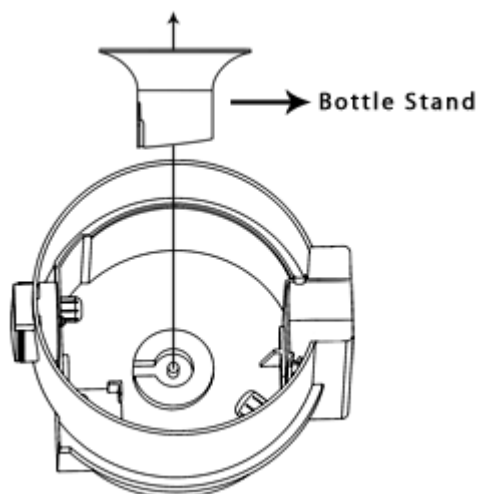

Fig 3

1.4

- ❑ Oval O-ring are factory installed on the bowl.

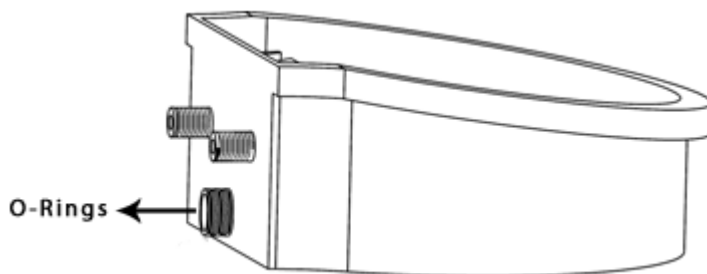

Fig 4

1.5

- ❑ Fix the Bowl to the base. Make sure that the oval water inlet tube aligns with the oval hole provided in front of the base.

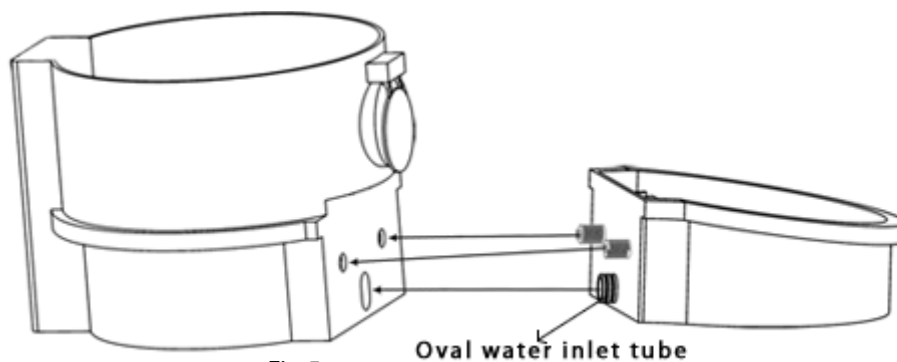

Fig 5

1.6

- ❑ Hand tighten the bowl with two plastic nuts provided.

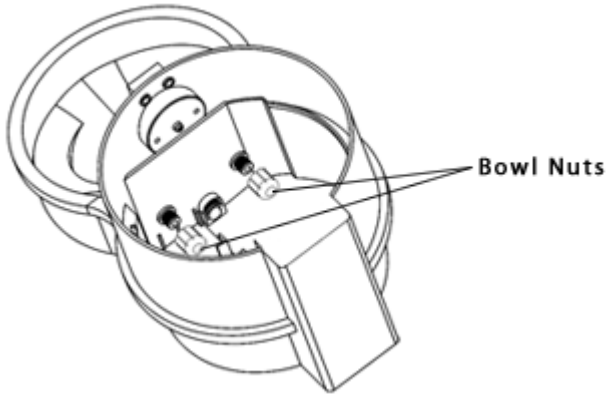

Fig 6

1.7

- ❑ Fix the Pre-filter next to the pump.

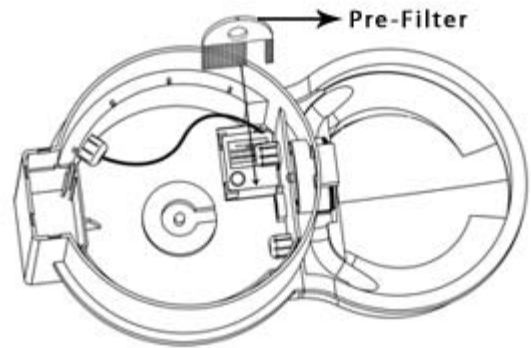

Fig 7

1.8

- ❑ Connect one end of the flow pipe with the filter cap and other end to the pump.

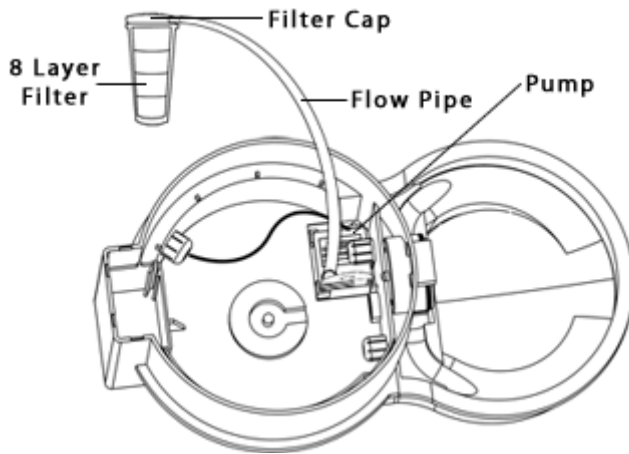

Fig 8

1.9

- ❑ Insert the filter connected flow pipe and filter cap into the filter compartment.

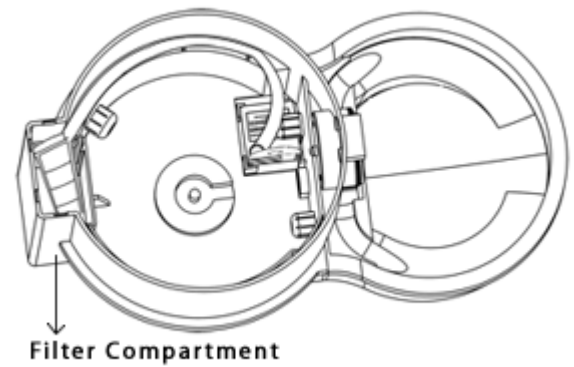

Fig 9

1.10

- ❑ Fix the filter cover over the filter compartment.

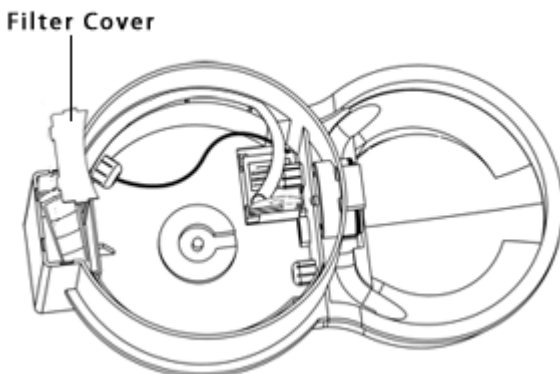

Fig 10

1.11

- ❑ Insert the flow tube into the opening in the body and push, so that it snaps into place. **THIS FLOW TUBE MUST BE INSTALLED FOR THE FILTERED PET WATERER TO FUNCTION PROPERLY.**

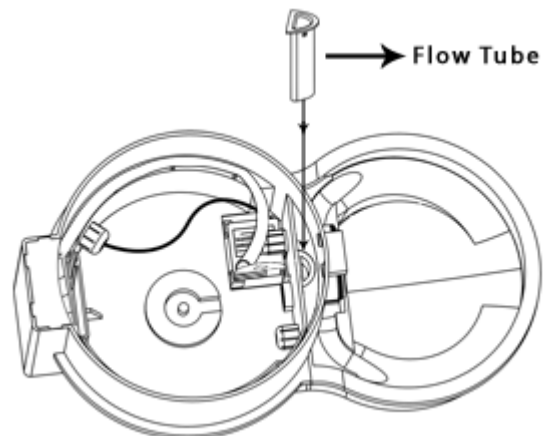

Fig 11

1.12

- ❑ Fix the bottle stand aligning the gap at the edge of the bottle stand with the gap in the rim inside the base.

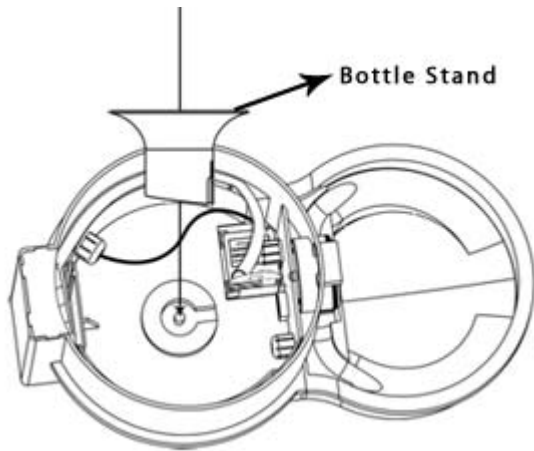

Fig 12

1.13

- ❑ Fill the water storage bottle (container) with water and place in base.

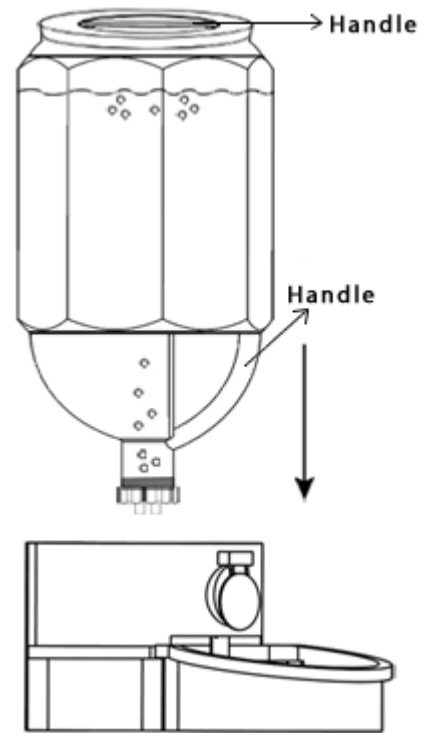

Fig 13

1.14

- ❑ Plug the transformer into 120 VAC outlet.

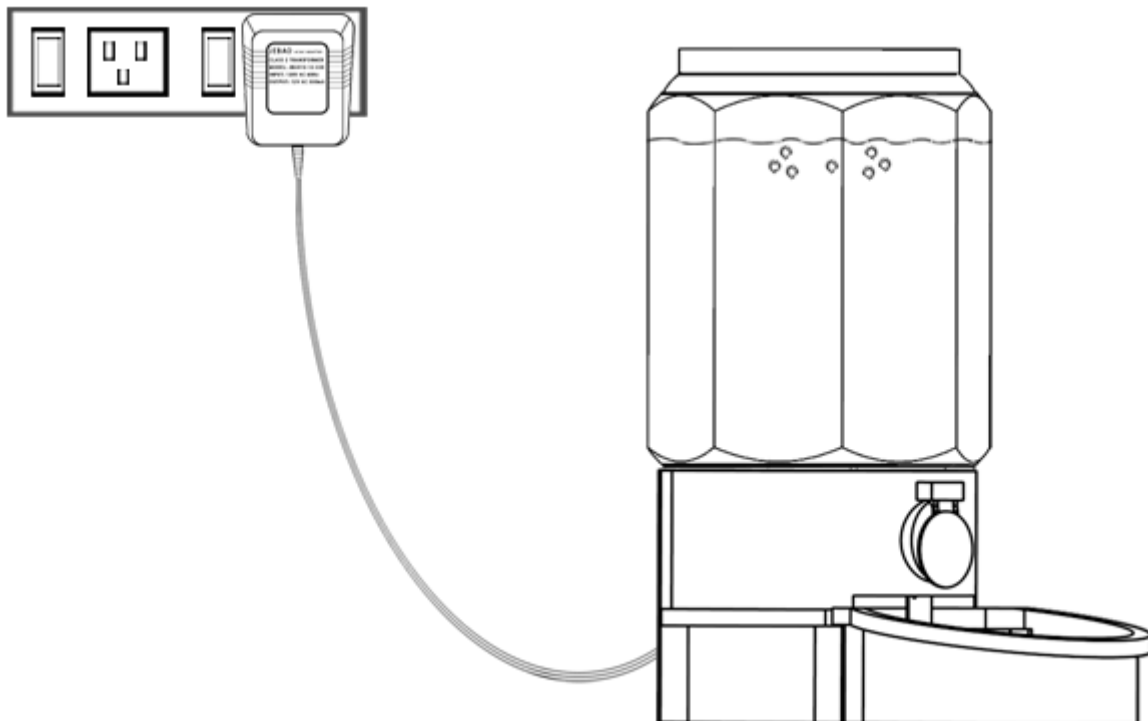
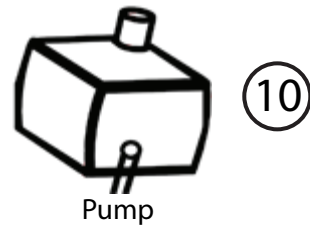
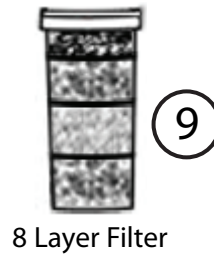
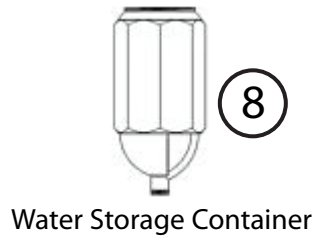
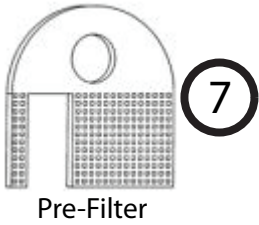
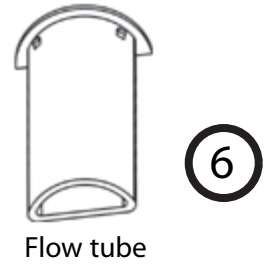
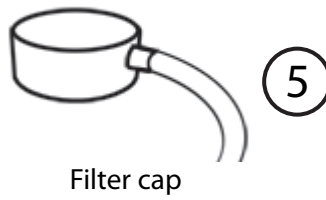
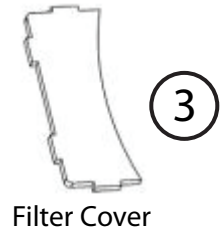
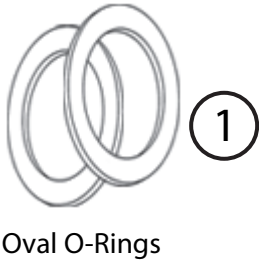

Fig 14

Now the FILTERED PET WATERER is ready to provide your pet clean oxygenated water.

LIST OF PARTS TO BE HAND WASHED



LIST OF PARTS THAT ARE DISH WASHER SAFE

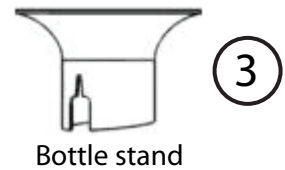
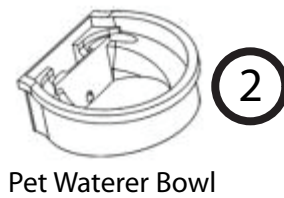
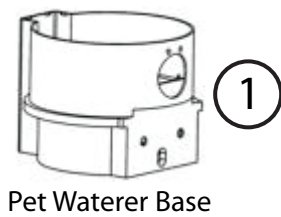

Maintenance

**Your Filtered Pet Waterer is easy to dismantle, clean and to re-assemble. The Filtered Pet Waterer should normally be cleaned every 15 days.
The following steps will make your cleaning process easier.**

Step 1

- ❑ The transformer should be disconnected from the power outlet and the pump wire should be disconnected from the transformer before cleaning.

Step 2

- ❑ Dismantle the base, bottle and bowl from the filtered pet waterer. Use mild soap like dish washing detergent to wash the inside of the bowl, bottle and body in the waterer. Finally wash and rinse the bowl, bottle and body together in warm water.

Step 3

- ❑ The external parts and base should be wiped down before reassembling.

Step 4

- ❑ For longer life of filter, clean the pre filter and 8 layered filter once a week. 8 layered filter can be cleaned by back flushing it in running tap water.

Step 5

- ❑ If the water flow decreases, replace the 8 layered filter.

Note : 1.The pump cover should not be opened for cleaning.
2.Please do not try to twist or turn to open the top lid. It is just a design to match the feeder and is not a lid for the bottle.

FAQ

1. What size Filtered Pet waterer should I purchase?

- The small pet waterer is recommended for pets which weigh less than 15 lbs. The medium pet waterer is recommended for pets which weigh greater than 15 lbs. and less than 40 lbs. The large pet waterer is recommended for pets weighing greater than 40 lbs.

2. How much water can I store in the Filtered Pet waterer?

- You can store approximately 5 gallons of water in the larger and 3 gallons in the medium and 2 gallons in the small.

3. Does the Filtered pet waterer have a pump?

- There is a low voltage pump inside the pet waterer. This pump runs continuously.

4. How does the Filtered pet waterer work?

- The water from the bowl is drawn through the hole in the bowl and then through the Pre-filter to the pump. The pump then injects air into the water and pumps it to the filter. The filter then filters, cleans the water and removes odors. The water is then recirculated from the filter to the bowl.

5. Will the water stay clean?

- The combination of forced aeration and filtration keeps the water clean. This prevents algae formation. This is unlike any other filtration system in the market.

6. How often do I have to replace the filters?

- It is recommended that the pet waterer filters be replaced at least once in 6-8 weeks. The filter life is dependent on your pet. Also make sure that you clean the pre-filter in the body every week. This will make the filter last longer.

7. Can I reuse the filter?

- Unlike other filters that have to be disposed, it is possible that the waterer filter life can be extended. If the filter is washed, back flushed and rinsed in hot water every week or when the water is refilled in the pet waterer storage container, the life of the filter can be extended.

8. What materials are used in the construction of the Filtered Pet waterer?

- All components in the feeder is made of rubber and plastic.

9. Does the Filtered Pet Waterer make any noise?

- The Filtered Pet Waterer has been designed with a semi-submersible whisper quite pump. There is no sound except for a quite hum that cannot be heard as much as felt by hand.

10. How do I clean the Filtered pet waterer?

- Make sure the pump is unplugged from the transformer. Take out the water storage container from the pet waterer. Wash and rinse the bowl and body together. You can use mild soap like dish washing detergent to wash the inside of the bowl and body. Make sure that you rinse well, (do not leave any soap residue in the unit). Make sure that you clean the filter and the filter chamber also. Place the assembly on a level floor and refill the storage container. Center the storage container in the middle of the body and place the bottle into the body. As the bottle rests in place, water will start flowing into the bowl. Plug the pump into the transformer and you are done.

11. Why does the pump make a noise?

- The Auto pet waterer has been designed with a semi-submersible whisper quite pump. If the Auto pet waterer does not have any water in the bowl the pump could possibly make a significant noise to disturb your pet. This is a warning for the pet owner to refill the storage bottle. If the noise is persistent even with the bowl with 3/4 inch of water then rotate the air suction cap on the motor to reduce this noise. (Round cap with small tube sticking up in the air)
- This noise may be generated due to too much air being sucked in. If this does not solve the problem please call us at 1-888-ERGOSYS..

12. Why does my Filtered Pet Waterer have a water level greater than 3/4 inch in the bowl?

- The Auto pet waterer has been designed to maintain 1/2 to 3/4 inch water level in the bowl. If the water level in the storage container is very low then the check valve will not function, because there is not enough water pressure in the storage container. This will cause the water level in the bowl to increase. Fill up the storage container with water and this should solve the problem.

13. Why is there water over the floor when the water level in bowl is less than 3/4 inch?

- There are two possible reasons for this.
 1. Turn off the pump and see if the leak persists. If the leak has stopped then check to see if the flow tube has been installed properly. (Half moon shaped piece part # 12 see operating/assembly instructions). If this is not installed and or lost please call us 1-888-ERGOSYS.
 2. Turn off the pump and see if the leak persists. If the Waterer continues to leak then the possibility is that the seals installed on the bowl prior to assembling the bowl to the body was not installed properly.
- Take out the storage container and lift the body/bowl combination up to see if there is a water leak between the bowl and body. If so take the bowl apart from the body (see operating /assembly instructions). Replace the O-rings on the bowl, apply a tiny bit of petroleum jelly on the O-rings and assemble the bowl and body back together. If you do not have any O-rings please call us 1-888-ERGOSYS.

14. What is the power of the pump in the Filtered Pet Waterer?

- The Filtered Pet Waterer has a 2 watt pump.

15. Is the Filtered Pet Waterer pump UL approved?

- The Filtered Pet Waterer pump is UL and CUL approved.

Ergo Systems Inc.,

E-Mail
support@ergosys.net

Toll-Free Phone. US only
1-888-ERGOSYS
(1-888-374-6797)

Website
<http://www.autopetfeeder.com>

International Phone
1-630-543-7686



Warranty Registration
<http://www.autopetfeeder.com/warranty.asp>

Fax
1-866-899-5389